



Technical Bulletin / Safety Alert

Unique ID No: DES2011-TBSA-07

Rev: 0

Subject: MDA DES 13017 Purifier Stud – Part Supercession

Date: 03/11/2011

Applicable to: VLI Diesel Pty Ltd Diesel Engine Systems covered under design approval no. MDA DES 13017 (Driftrunner & Brumby)

Note: Minimum PPE required to carry out any inspections contained in this TBSA shall be protective clothing & footwear, safety glasses, hearing protection & any site specific requirements. A JSA or equivalent should be carried out prior to performing these tasks.

Description:

Valley Longwall International Diesel Division (VLIDD) wish to advise of the following part supercession in relation to the optional purifier assembly (Part No. 5-04100601) applicable to diesel engine systems covered under design approval no. MDA DES 13017:

Existing Part: 5-04115102 Purifier Stud

Replacement Part: 5-04115105 Purifier Bolt

The bolt is a direct replacement for the stud assembly. The bolt is intended to provide improvement for the fastening of the optional purifier assembly where installed. The existing stud assembly can still be used and the integrity of the installation will not be affected when maintained in accordance with OEM recommendations.

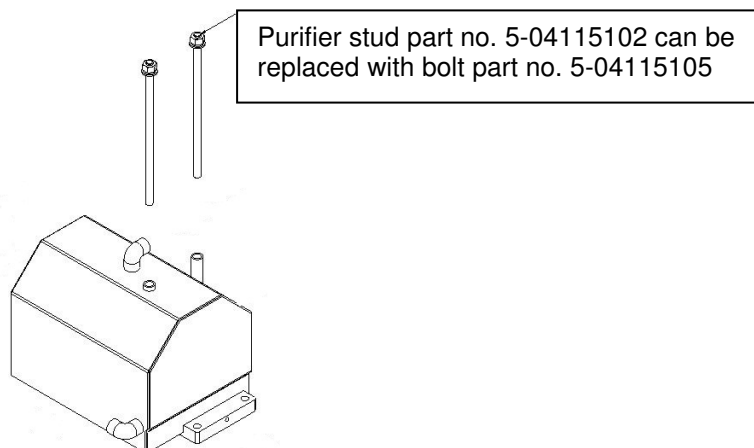

Immediate Action:

NIL

Future Action:

Where optional purifier assemblies are installed, it is recommended the new purifier bolt (5-04115105) replace the existing stud assembly (5-04115102) at the next Code D mechanical inspection. The installation torque for the bolt remains the same as that of the stud, at 77Nm.

Maintenance Considerations:

The existing service and maintenance intervals for the diesel engine system remain unchanged whether the stud or the bolt is installed. The explosion protected integrity of the diesel engine exhaust system is not affected when maintained and serviced in accordance with OEM recommendations.

Please ensure this document is circulated to all relevant personnel within your organisation.

Should you have any further queries please contact your VLI Diesel Representative.

Tomago Operation
28 Old Punt Road
Tomago NSW 2322
P: +61 2 4913 7500
F: +61 2 4964 8919

Rutherford Operation
20 Shipley Drive
Rutherford NSW 2320
P: +61 2 4015 3200
F: +61 2 4932 1722

Mackay Operation
6 Fursden Street
Glenella QLD 4740
P: +61 7 4942 7495
F: +61 7 4942 4944

Emerald Operation
44 Industrial Drive
Emerald QLD 4720
P: +61 7 4987 5011
F: +61 7 4987 4711