

# GENERAL PURPOSE MOTOR



- Pneumatic motor
- Ideal for hazardous areas to drive auxiliary equipment or wherever hydraulic power unavailable
- Delivers full power at stall, unlike hydraulic motors, this causes no damage to unit
- Available in different configurations to suit requirement
- Available with unique muffler, for low noise and minimised misting



Supplied with SAE  
2-bolt flange  
for easy replacement  
of hydraulic motors

Powerful pneumatic motor  
suitable for a variety of  
applications

# GENERAL PURPOSE MOTOR

## Operational Information

The RAMBOR General Purpose (GP) Motor is a robust pneumatic motor suitable for a range of above and below ground applications. The GP Motor has track-record for being a low maintenance and reliable means to drive conveyors, Longwalls, mixers, winches and pumps.

The Motor/Gear Box Drive is available with a unique silencer system which ensures that oil misting on discharge is kept to an absolute minimum and noise levels have registered as low as 86 dB(A).

The RAMBOR GP Motor is available in a number of different motor/gearbox configurations. The model pictured (below) is fitted with 2-bolt flange and muffler unit; other options are available to meet specific customer applications.

## Specifications

All Figures at 7 Bar (100psi) Air Supply Pressure	70mm Motor with 11-42 ratio gearbox	70 mm Motor with 14-39 ratio gearbox
Rambor Part Number	1590-0006	1590-0007
Stall Torque	271 Nm (200 ft/lbs)	203 Nm (150 ft/lbs)
Max Speed	700 rpm	900 rpm
Max Air Consumption	3115 l/min (110 cfm)	
Noise Level (with muffler)	86-95 dB(A)	
Weight	15 kg (33 lbs)	

All Figures at 7 Bar (100psi) Air Supply Pressure	95mm Motor with 11-42 ratio gearbox	95 mm Motor with 14-39 ratio gearbox
Rambor Part Number	1590-0008	1590-0009
Stall Torque	325 Nm (240 ft/lbs)	251 Nm (185 ft/lbs)
Max Speed	600 rpm	850 rpm
Max Air Consumption	5664 l/min (200 cfm)	
Noise Level (with muffler)	86-95 dB(A)	
Weight	17 kg (37.5 lbs)	

## Dimensions in mm

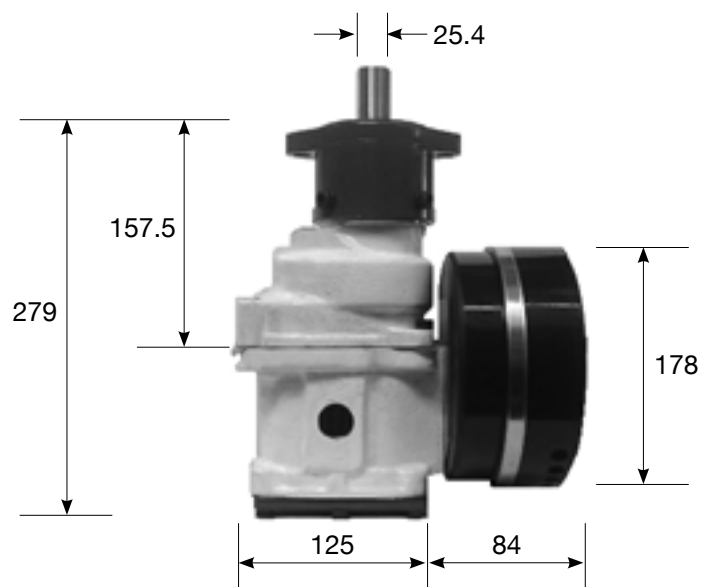

**RAMBOR**

108 Albatross Rd South Nowra, 2541 NSW AUSTRALIA  
+61 2 4422 6323 info@rambor.com.au www.rambor.com.au

